



## TWO MEDIUM-RING NOZZLE

The two-medium ring nozzle is especially used for very low throughput rates (ml/h) as well as for media of higher viscosity. Normally, the medium to be atomized is closed. This nozzle allows even moistening of a cylindrical surface.

### RING NOZZLE FLAT CONE

size 1 + 2



### CAPACITY

In each case, the throughput rate is determined by the pressure of the atomized air and the medium. Depending on the medium, the nozzle pressure for the medium amounts to 1,0 to 5,0 bar, for the compressed air 0,5 to 4,5 bar.

### POSSIBLE APPLICATIONS

Surface treatment for cylinders  
cooling  
lubrication  
laboratory tests  
conservation

### AVAILABLE IN THE FOLLOWING MATERIALS

brass

### DIMENSIONS

	ØA mm	B mm	ØC mm	ØD mm
size 1	94	82	60	62
size 2	112	100	78	80

radial connections also available

other dimensions on request.

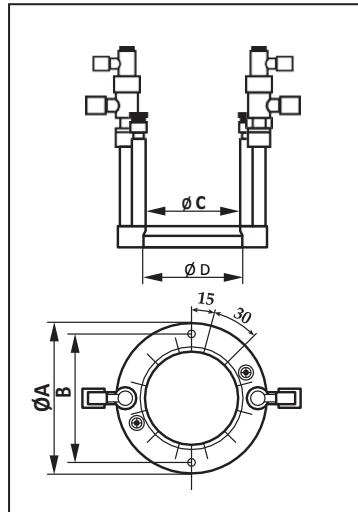

### FOR YOUR ORDERING WE NEED THE FOLLOWING INFORMATION

#### Field of application

medium to spray (viscosity)  
fitting position / spray distance nozzle – spray area  
temperature range  
frequency range

#### Nozzle specification

nozzle type  
desired capacity (l/min, l/h)  
operating pressure in bar (air and medium)  
feeding of medium